



**Ball Valves PN 20/50 (Class 150/300)
Metal Seated Construction
Floating Ball**



Fig. 3515/3530
Metal Seated Valve
API 6D and Fire Safe

Manufacturing program:

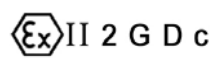

LICENSE NO. 6D-0197

Quality & Environmental Management:





Ball Valves PN 20/50 (Class 150/300)

DN 15 - 200 (½" – 8") PN 20 (Class 150)

DN 15 - 150 (½" – 6") PN 50 (Class 300)

Parts and materials

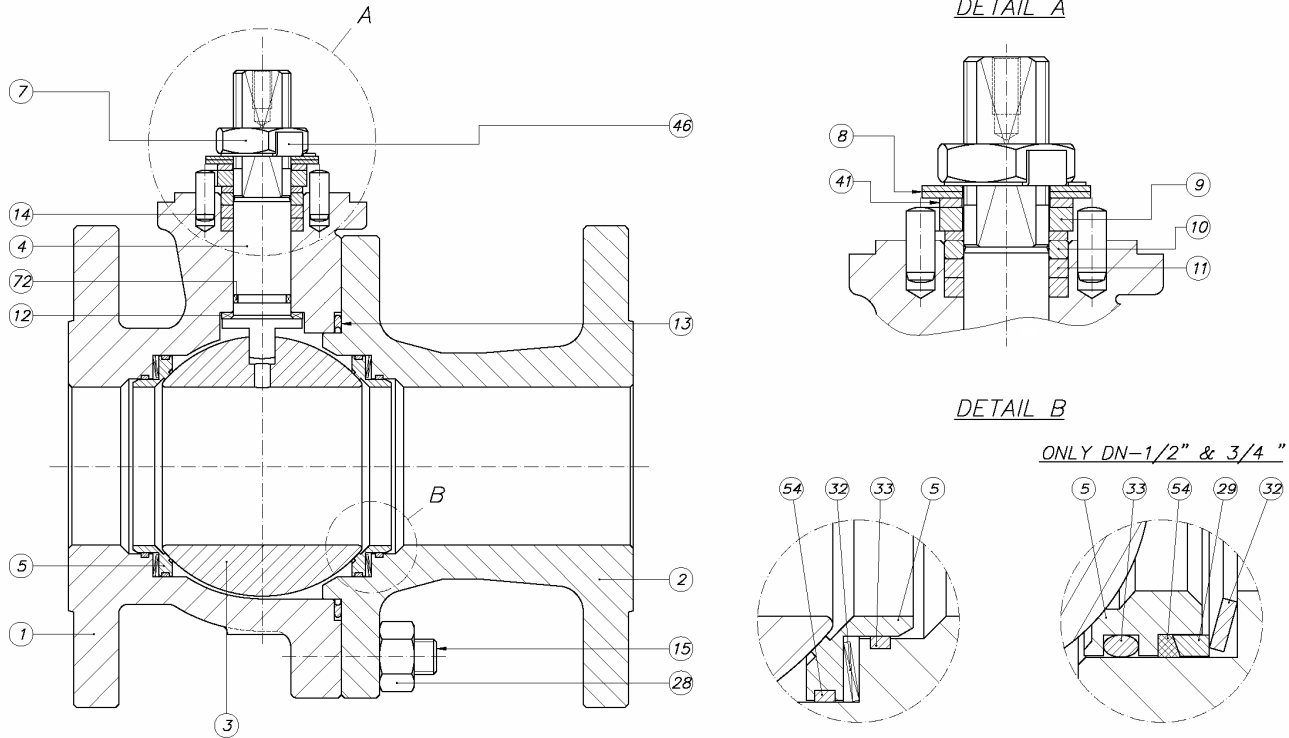

Item	Description	Material	
		AIM	IIM
1	Body	A216 Gr.WCB (C≤0,25%)	A351 Gr. CF8M
2	Body connector	A216 Gr.WCB (C≤0,25%)	A351 Gr. CF8M
3	Ball	316 S.S. + HT-65 Lapped	
4	Stem	See options	
5	Seat ring	316 S.S. + HT-65 Lapped	
7	Gland nut	Zinc plated carbon steel	AISI 303
8	Disk spring	Carbon steel	ENP Carbon Steel
9	Stop plate	Carbon steel	AISI 304
10	Gland	AISI 303	AISI 316
11	Gland packing	Graphite	
12	Stem thrust seal	316 S.S. + HT-65	
13	Body connector seal	AISI 316L +Graphite	
14	Stop pin	Carbon St.	Stainless St.
15	Stud	A193Gr. B7M	A193 Gr. B8M
28	Nut	A194 Gr. 2HM	A194 Gr. 8M
29	Washer (Only DN-15" & 20")	316 S.S. + HT-65	
32	Seat disk spring	Inconel X-750	
33	Seat Seal	See options	
41	Spacer (DN 40 to DN200)	Carbon steel	AISI 304
46	Locking washer	AISI 304	
54	Seat Seal	Graphite	
72	Stem "O" Ring	See options	

OPTIONS

#3 BALL - SLURRY OPTION

#4 STEM - 17-4PH,
NITRONIC 50, 316 S.S.

#5 SEAT RING - PAPER & PULP
OPTION

#33 SEAT SEAL & 72 STEM
"O" RING – FKM, AFLAS,
KALREZ (4079, 6375, 7075)
MAXIMUM TEMPERATURE
FOR KALREZ 7075 327°C
(620°F)



Ball Valves PN 20/50 (Class 150/300)

DN 15 - 200 (½" – 8") PN 20 (Class 150)

DN 15 - 150 (½" – 6") PN 50 (Class 300)

Dimensions

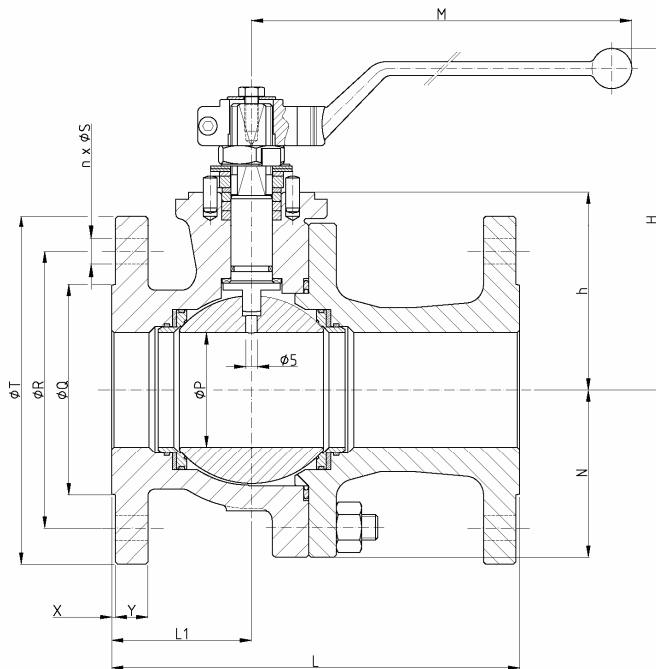

ONLY DN 15 (1/2") & DN 20 (3/4")

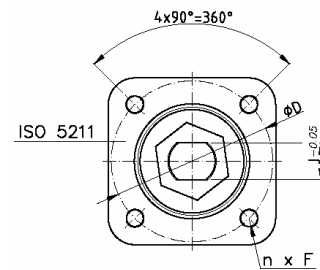
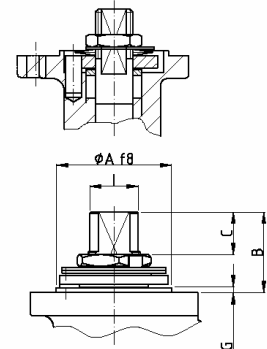

Class 150 Series

DN	ØP	L	L1	ØQ	ØR	n x ØS	ØT	X	Y	h	N	H	M	WEIGHT
15 (½")	15	108	47	34,9	60,3	4x15,9	88,9	1,6	9,5	46	---	98	224	2
20 (¾")	20	117	50	42,9	69,8	4x15,9	98,4	1,6	11,1	53	---	107	224	3
25 (1")	25	127	52	50,8	79,4	4x15,9	108	1,6	12,7	58	---	118	224	3,5
40 (1½")	40	165	65	73	98,4	4x15,9	127	1,6	15,9	76	---	148	315	8
50 (2")	50	178	68,5	92	120,6	4x19	152	1,6	17,5	83,5	---	156	315	11
65 (2½")	65	190	75	104,8	139,7	4x19	177,8	1,6	20,6	97	---	169	348	16
80 (3")	80	203	90	127	152,4	4x19	191	1,6	22,2	111	---	207	445	23
100 (4")	100	229	102	157,2	190,5	8x19	229	1,6	22,2	133	120	231	495	38
150 (6")	151	394	160	211,3	241,3	8x22,2	279,5	1,6	23,8	183	168	297	698	88
200 (8")	203	457	209	270	298,4	8x22,2	343	1,6	27	233	208	351	868	155

(*) Dimensions in mm and weight in kg.

Class 300 Series

DN	ØP	L	L1	ØQ	ØR	n x ØS	ØT	X	Y	h	N	H	M	WEIGHT
15 (½")	15	140	60	34,9	66,7	4x15,9	95,2	1,6	12,7	46	---	98	224	3
20 (¾")	20	152	65	42,9	82,5	4x19	117,5	1,6	14,3	53	---	107	224	4
25 (1")	25	165	70	50,8	88,9	4x19	123,8	1,6	15,9	58	---	118	224	5
40 (1½")	40	190	80	73	114,3	4x22,2	155,6	1,6	19	76	---	148	315	11
50 (2")	50	216	87	92	127	8x19	165,1	1,6	20,6	83,5	---	156	315	14
80 (3")	80	283	118	127	168,3	8x22,2	210,5	1,6	26,9	111	---	207	445	32
100 (4")	100	305	130	157,2	200	8x22,2	254	1,6	30,2	133	120	231	495	52
150 (6")	151	403	160	216	269,9	12x22,2	317,5	1,6	35	183	168	297	698	94

(*) Dimensions in mm and weight in kg.

Actuator connection

DN	ISO 5211	ØA	B	C	ØD	n x F	G	I	J
15 (½")	F05	35	11,5	5,7	50	4x M6	1,5	M12x1.5	9
20 (¾")	F05	35	15	7,4	50	4x M6	1,5	M12x1.5	9
25 (1")	F05	35	24	10,2	50	4x M6	1,5	M12x1.5	9
40 (1½")	F07	55	39,5	16,7	70	4xM8	3	M18x1.5	13
50 (2")	F07	55	41,5	17,6	70	4x M8	3	M18x1.5	13
65 (2½")	F07	55	44	18,1	70	4xM8	3	M22x1.5	16
80 (3")	F10	70	44,5	18,7	102	4xM10	3	M25x1.5	18
100 (4")	F10	70	56,5	28,7	102	4xM10	3	M28x1.5	20
150 (6")	F12	85	68	38,5	125	4xM12	3	M40x1.5	29
200 (8")	F14	100	70	37	140	4xM16	4	M45x2	32

(*) Dimensions in mm and weight in kg.



Ball Valves PN 20/50 (Class 150/300)

DN 15 - 200 (½" – 8") PN 20 (Class 150)

DN 15 - 150 (½" – 6") PN 50 (Class 300)

General Characteristics, Torque&KV, P&T Rating

GENERAL CHARACTERISTICS	Fig 33515/3530 Series SFF Split Body	Floating Ball	Full Bore		
DESIGN STANDARDS					
Valves design	API 6D / ISO 14313	ASME B16.34	BS 5351	NF E 29-470	ISO 17292
Body design	ASME VIII Div.1				
Shell thickness	ASME B16.34	BS 5351	ISO 17292		
Flanges	ASME B16.5 Raised face				
Face to face dimensions	ASME B16.10 Long pattern	API 6D / ISO 14313	EN 558-2 Series 3, 4 & 12		
Actuator mounting flange	ISO 5211				
Wetted parts materials and bolting	NACE MR.01.75				
Shell finishing quality	MSS SP 55				
Marking	API 6D / ISO 14313	BS 5351	ISO 17292	CE - PED	EN 19
TESTS AND CERTIFICATES					
Quality Assurance	ISO 9001	API Q1	CE - PED		
Fire Safe design	BS 6755 Part 2	API 6FA	ISO 10497	API 607 4 TH Edition	
Pressure testing	API 598	BS 6755 Part 1	ISO 5208 / ISO 17292	NF E 29-203	EN 12266
Other	ISO 14001	ATEX			

Torque Values in Nm

VALVE SIZE	AT DIFFERENTIAL PRESSURE		VALVE SIZE	AT DIFFERENTIAL PRESSURE	
	Class 150	Class 300		Class 150	Class 300
	20 bar	50 bar		20 bar	50 bar
DN 15 (½")	26	32	DN 65 (2½")	140	
DN 20 (¾")	32	40	DN 80 (3")	170	286
DN 25 (1")	38	45	DN 100 (4")	273	
DN 40 (1½")	55	70	DN 150 (6")	778	
DN 50 (2")	92	135	DN 200 (8")	1313	

Kv Values in m³/h

DN 15 (½")	DN 20 (¾")	DN 25 (1")	DN 40 (1½")	DN 50 (2")
20	40	75	170	270
DN 65 (2½")	DN 80 (3")	DN 100 (4")	DN 150 (6")	DN 200 (8")
550	1000	1650	4200	9000

Pressure-Temperature

